



Quick Start

Set Up

A

Receiver (Serial)

Installation Overview **Basic Installation**

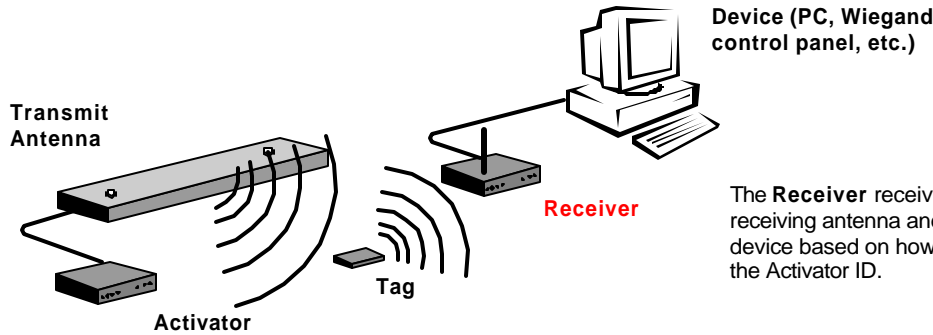

The **Receiver** receives the Tag's broadcast signal via its receiving antenna and sends the Tag data to a PC or control device based on how it has been programmed to respond to the Activator ID.

1

Connecting Power

All Receivers come with a 4.4 VDC, 400 mA power transformer that plugs into a 110 VAC outlet. If uninterruptible power is an issue, a backup battery or UPS can be used. Alternative power may be obtained by the 24 VDC, 400 mA connector located on the back panel.

- Step 1:** Ensure that the 110V AC outlet is near the Receiver and is easily accessible.
- Step 2:** Plug the AC adapter into the jack labeled 5 VDC on the back of the Receiver.
- Step 3:** Plug the unit into the power outlet.

When power is supplied, the *PWR* LED on the front of the unit will light up.

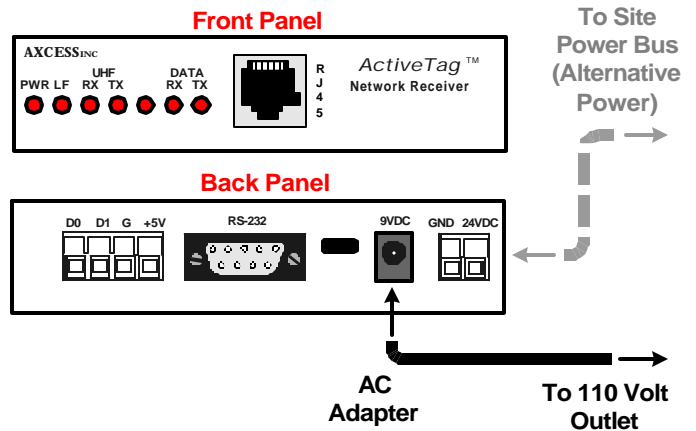

2

Setting the Receiver ID

Receiver IDs are used by ActiveTrac software to determine from which zone a Tag reported.

DEFAULT: 001

Action	Command
Give the Receiver a new ID	<number> I

Where <number> is between 000 and 999.

Modifying Default Settings

Required Materials

- A computer with a terminal program and a free communications port.
- A standard one-to-one (straight-through) computer modem RS-232 cable with a DB-9 male connector (Receiver end) and a suitable connector for the PC/terminal.

DO NOT use a null-modem cable or null-modem adapter.

Connecting a PC to the Receiver

- Step 1:** Attach the DB9 male connector of the RS-232 cable to the RS-232 port on the Receiver.
- Step 2:** Attach the other end of the RS-232 cable to the computer.

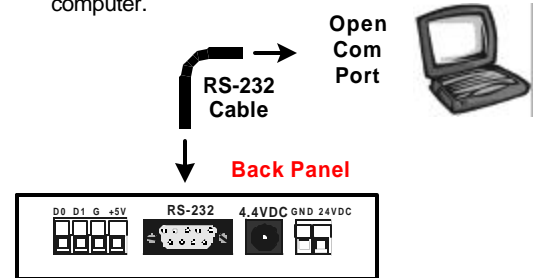

Communicating via HyperTerminal

- Step 1:** From the Start button on the desktop, Select: **Programs** → **Accessories** → **Communications** → **HyperTerminal**.
- Step 2:** Double-click the Hypertrm.exe icon to launch application.

750.010.003 R03



3208 Commander Drive, Carrollton, Texas 75006
 800.588.6080 / FAX: 972.407.9085
 technical support: 800.577.6080
 www.axcessinc.com

Receiver (Serial)

Quick Start

Set Up



Receiver (Serial)

Step 3: Enter any name for the connection and select the first icon and click **OK**.



Step 4: Select the com port to which the Receiver is connected from the



Step 5: Enter the following information in the *Com Properties* dialog box:

Bits per second 19200
 Data Bits 8
 Parity None
 Stop Bits 1
 Flow Control None

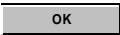
Step 6: Click 

Receiver Responses

Command basic format: **<number><command>**

 It is not necessary to press the Return key after typing a command.

When a command is given to the Receiver, the Receiver will respond with one of the following responses:

Command	Receiver code Responses
00	Command completed successfully
05	Value entered is out of bounds
06	Invalid or unknown command

3 Setting Up a Serial or LAN System

Setting the Baud Rate

The following commands are available for configuring the Receiver's serial port:

Action	Command
Set baud rate to 4800	23c
Set baud rate to 9600	24c
Set baud rate to 19200 (default)	25c

Serial Output

Long format: Default

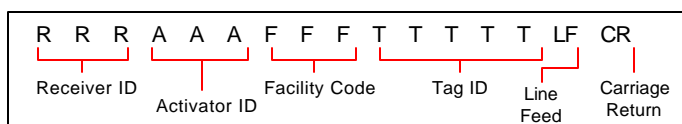

Optimizing Serial Output

The speed at which the Receiver processes data can be maximized by eliminating extra steps required to output Wiegand data and check TTL output control settings.

Action	Command
Turn off Receiver's Wiegand output	29c
Restore Wiegand output (default)	15c
Disable TTL outputs (If your installation does not require them)	35c
Restore TTL output operations	20c

 When the Network Receiver is sending data via the serial port, the LED labeled DATA TX will alternately flash from red to green. Observing this LED on the front of the unit will help in verifying proper operation of the Network Receiver.

Responding to Activator IDs

The only Tag data that a Receiver will output via the serial port must contain a valid Activator ID.

By default, the Receiver accepts Tag data from Activators with the following IDs:

3	34	70	103	13	44
72	105	14	47	75	106
21	52	80	113	22	55
83	114	24	57	93	124
27	58	94	127	33	69
100					

Editing Activator IDs within the Receiver

Editing Actions

Action	Command
Delete unwanted ID(s) from Receiver's list	<number>-
Remove all accepted Activator IDs (Receiver will still pass default ID 127)	37c
Add an Activator ID	<number>+
Reset the list to the valid Activator ID numbers	34c

Error Codes

Code	Reason
04	Trying to delete an ID that has not been programmed
03	Trying to delete all IDs. There must be at least one
02	Trying to enter more than 34 IDs - the maximum

4 Enabling TTL Outputs (Logic Control)

The Receiver has 2 Transistor-Transistor-Logic (TTL) outputs - each can be set to go from Low (inactive) to High (active) upon a tag read. The output level is 3.3V DC.

Configuration

TTL Output 1	TTL Output 2	Action
<number>D	<number>E	Set length of action signal in seconds. Valid numbers are 000 - 255. Default: 005 seconds
10c	11c	Set output to go from Low to High
16c	17c	Do not activate TTL output for a valid Tag read. Default.
30c	31c	Activate TTL output for a valid Tag read.
13c	14c	Do not activate TTL output when alarm code received from a Panic or Tamper Tag. Default.
27c	28c	Activate TTL output when alarm code received from Panic or Tamper Tag.