

Activator

Installation Manual

Notices

Information provided in this manual is a result of the design and development of AXCESS Inc. products and is subject to change without notice. It applies only to current AXCESS Inc. RFID systems.

No part of this manual may be reproduced, translated or transmitted, in any form or by any means, without the prior written consent of AXCESS Inc.

FCC Rules

Note: This equipment has been tested and found to comply with the limits for a Class B digital device, pursuant to Part 15 of the FCC Rules. These limits are designed to provide reasonable protection against harmful interference in a residential installation. This equipment generates, uses, and can radiate radio frequency energy and, if not installed and used in accordance with the instructions, may cause harmful interference to radio communications. However, there is no guarantee that interference will not occur in a particular installation. If this equipment does cause harmful interference to radio or television reception, which can be determined by turning the equipment off and on, the user is encouraged to try to correct the interference by one or more of the following measures:

- Re-orient or relocate the activation antenna
- Increase the separation between the equipment and activator
- Connect the equipment into an outlet on a circuit different from that to which the receiver is connected
- Consult the dealer or an experienced radio/TV technician for help

Responsibilities

- AXCESS Inc. declines all liability for any damage that might result from any errors or omissions in this document or from improper installation.
- AXCESS Inc. can only guarantee the correct operation of its products if they are used with the software programs, systems, and consumables supplied or authorized in writing by AXCESS Inc.
- AXCESS Inc. recommends keeping the original packaging for transporting the equipment later.

Registered Trademarks

Product names mentioned herein may be trademarks and/or registered trademarks of their respective companies.

Customer Service

AXCESS Inc. toll-free support line is 1-800-577-6080.

Table of Contents

GENERAL INSTALLATION INFORMATION	4
SAFETY	4
INFORMATION FLAGS.....	4
HAND TOOLS, EQUIPMENT AND MATERIALS.....	5
<i>Provided Materials</i>	5
<i>Required Materials</i>	5
<i>Recommended</i>	6
OVERVIEW	7
SPECIFICATIONS	7
FEATURES.....	7
CONFIGURING THE ACTIVATOR	9
CONNECTING POWER.....	9
SETTING THE ACTIVATOR ID	10
SERIAL PORT COMMANDS	15
<i>Receiving Help</i>	15
<i>Changing the Baud Rate</i>	15
ACTIVATOR INSTALLATION.....	16
REQUIRED MATERIALS	16
MOUNTING THE ACTIVATOR.....	16
ACTIVATION FIELD SIZE.....	17
<i>Adjusting the Field</i>	17
INDEX	18

General Installation Information

Safety

Personal safety is of first importance in the performance of any job.

- Installation and configuration of the ActiveTag system should only be performed by experienced installers.
- Where practical or required by code, all wiring should be enclosed in conduit, or equivalent protection, firmly anchored to sturdy structural elements and protected from mechanical damage.
- Hand tools should be of good quality and properly maintained.
- Hand tools should be used in the applications for which they were intended.
- Always wear eye protection when using power tools.
- When drilling or cutting, do not damage wires, pipes or structural components.
- When installing antennas and related equipment above a ceiling, make sure they are properly attached to a structural member and accessible for maintenance.

Information Flags

Information flags in this document draw your attention to important information:



IMPORTANT!

Provides essential information to the user that will ensure proper operation of the hardware or software. If this advice is not followed, system recovery can be difficult or time-consuming. **ALWAYS READ THESE ITEMS.**

NOTE

Provides helpful information that can make the installation go more smoothly and quickly.



TIP

Provides useful information to the user on a particular procedure or technique.

Hand Tools, Equipment and Materials

The following are provided, required and recommended hand tools, equipment and materials necessary for the successful configuration and installation of the Activator:

Provided Materials

Unpack the Activator. The following items are included with each unit:

- Activator Transmitter
- AC/DC plug-in transformer with connector
- Tuning Tool

Required Materials

- RG-58/U coaxial cable with 50-ohm impedance (nominal), solid copper center conductor, 55% tinned copper braid or better, 100% foil shield coverage (for example, Belden 9310). Finished length should be no more than 50 feet (20 feet max. if using the road loop lead wire). If installed outside, the cable should be rated for direct burial.
- 3-piece crimp type male BNC connectors (for example, Amphenol 31-320). Connectors can be damaged during crimping. Having more than two on hand for each cable made is recommended.
- A computer or terminal device to configure the Activator
- A terminal communication program such as HyperTerminal (standard with MS Windows installations)
- A straight-through (one-to-one) DB9 male to female serial cable.



IMPORTANT! DO NOT use a null-modem cable or a null-modem adapter.

- Tape measure
- Power drill and bits
- Phillips and flathead screwdrivers
- Needle-nose pliers
- Diagonal cutters
- Wire strippers
- Three blade rotary coaxial cable stripper
- BNC crimpers

Recommended

- Ladder
- Fishing line – 15 lb. test for pulling cable
- Tie wraps and anchors
- A pair of walkie-talkies if more than one installer will be on site
- Laptop computer to connect to the Activator easily
- Instructions for all third party devices

Overview

The Activator is a stand-alone transmitter that connects directly to an application-specific transmit antenna to provide low frequency activation signal that awakens tags as they pass through the antenna's field. The Activator writes its location ID to the tag, which is then retransmitted, along with the tag's unique ID to the Receiver. From this information, the Receiver uses the Activator ID to determine what action to take with the Tag data.

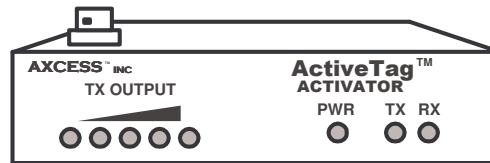

Figure 1 Front panel of the Activator

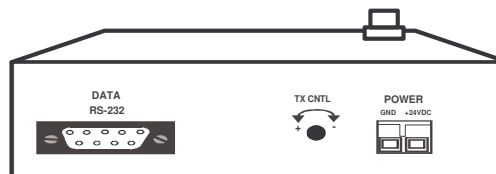

Figure 2 Back panel of the Activator

Specifications

Power

Adapter	120 V AC/24 V DC transformer
Input	24 V DC @ 1 Amp

Dimensions

Height	1.5 inches
Width	3.5 inches
Depth	6.5 inches

Weight	12 ounces
---------------	-----------

Operating Temperature	-40° to +185°F (-40° to +85°C)
------------------------------	--------------------------------

Features

The Activator has the following functions:

Control Point Architecture

Limits the tag activation to specific user-defined points or zones for tracking and control.

Adjustable Power

The Activator's activation zone can be sized using a simple tuning tool with exterior LED power-level indicators.

Signal Penetration

The Activator's low frequency signal penetrates briefcases, luggage, clothing, people, and virtually all non-metallic building materials.

Flexible Installation

The Activator connects directly to a wide variety of application-specific antennas at distances up to 50 feet away (we recommend this length be kept under 20 feet).

Configuring the Activator

The Activator can be configured with its own user-defined location ID via serial port (using a PC or terminal communications device) or manually via jumpers. The unit installs easily and offers flexible coverage for perimeter doors, interior zones, vehicle lanes and other control points throughout the facility.

The following items are necessary for the successful configuration of the Activator:

- A computer with a terminal program and a free communications port
- A standard one-to-one computer modem RS-232 cable with a DB9 male connector (Receiver end) and a suitable connector for the PC/terminal end



IMPORTANT! Do not use a null-modem cable or null-modem adapter.

Connecting Power

Activators come with a 24V DC, 1 Amp power transformer that plugs into a standard 110V AC outlet. The transformer is pre-wired into the terminal block at the factory. IF uninterruptible power is an issue, a backup battery or UPS can be used.



To connect power to the Activator

- 1: Connect the antenna to the Activator in order for the antenna auto-tune feature to function when power is applied. Auto-tune takes place each time power is cycled.
- 2: Plug the power terminal block into the back of the Activator (Figure 3).

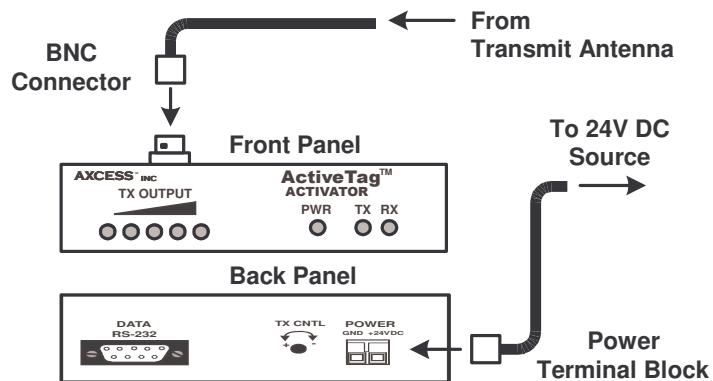

Figure 3 Connecting power to the Activator

- 3: Plug the AC adapter into a 110-volt outlet.

Setting the Activator ID

The Activator sends its ID number in the wake-up signal. The Tag then transmits both its own ID and the device ID of the Activator to the Receiver.



IMPORTANT! All Activators are given the same ID number (127) at the factory. Each Activator in a multi-Activator application needs to be set with a unique ID number to ensure proper behavior of the system.

An Activator ID can be set by two methods:

Method 1 – serial commands (requires a computer or terminal device). This is the preferred method of setting the Activator ID

Method 2 – hardware jumpers if no terminal is available

Required Materials

- A computer or portable terminal with a free communications port. A laptop is recommended because it can be taken into the field easily.
- A terminal program for communicating with an Activator. HyperTerminal is convenient since it is standard with the Windows™ based operating system. Other terminal emulation programs, such as ProComm, etc., can also be used.
- A standard one-to-one (straight-through) computer modem RS-232 cable with a DB9 male connector for the Receiver and suitable connector for the PC/terminal.



IMPORTANT! DO NOT use a null-modem cable or null-modem adapter.

Method 1: Serial Commands



To connect the computer to the Activator

- 1:** Ensure power is applied to the Activator.
- 2:** Attach the DB-9 male connector of the RS-232 cable to the Data RS-232 port on the back of the Activator.
- 3:** Attach the other end of the RS-232 cable to an open com port on the computer (Figure 4).

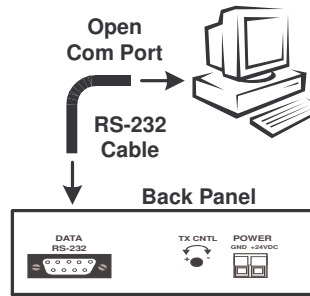

Figure 4 Connecting computer to the Activator

► To communicate via Windows HyperTerminal

- 1: From the Start button on the computer's desktop, select **Programs > Accessories > Communications > HyperTerminal**.
- 2: In the Explorer window that appears, double-click the Hypertrm.exe icon to launch the HyperTerminal application.
- 3: In the *Connection Description* dialog, enter any name of the connection and select the first icon in the Icon selection box; then click OK (Figure 5).

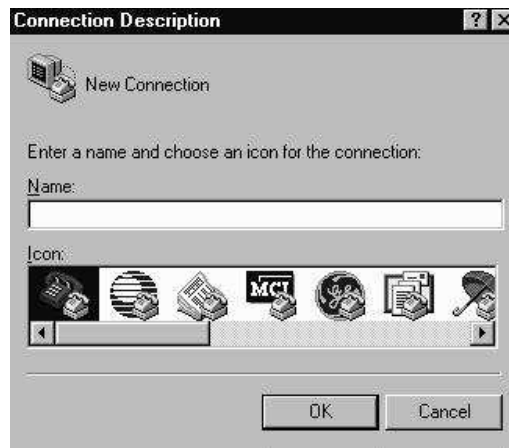

Figure 5 Enter a name for the connection

- 4: Select the com port to which the Activator is connected from the Connect Using drop-down list; then click OK (Figure 6).



Figure 6 Select a com port

5: Enter the following information in the *Com Properties* dialog box:

Bits per second (Baud) 19200
Data Bits 8
Parity None
Stop Bits 1
Flow Control None

6: Click OK.



To change the Activator ID number

If your ActiveTag system is using Version 5 Tags, type one of the default Activator ID numbers in Table 1 followed by an exclamation point "!". The number will be accepted as the Activator's ID number.

NOTE 127 is the default Activator ID.

3	34	70	103	13	44
72	105	14	47	75	106
21	52	80	113	22	55
83	114	24	57	93	124
27	58	94	127	33	69
100					

Table 1 Default Activator IDs programmed into the Network Receiver

If your ActiveTag system is using Version 6 or later tags, type any number between 1 and 250 followed by an exclamation point "!".

If you type: 113!
Activator response: ID = 113

Method 2: Hardware

When set with jumpers, the Activator ID is a binary number represented by jumpers. A **1** is represented by a jumper on the header and a **0** is represented by an absence of a jumper (Table 2).

Once an Activator ID is set by jumpers, it can **not** be reset with serial commands. In order for serial commands to take effect, the jumpers must be removed, the unit must be powered down and then rebooted. However, even with the jumpers removed the Activator will maintain the ID that had been set with jumpers until reprogrammed with the serial command.

NOTE Before the Activator ID is set with jumpers, the default ID is 127, although there are no jumpers on the headers.

ID#	Jumpers		ID#	Jumpers	
	JP19	JP12		JP19	JP12
3	0	0	70	0	1
13	0	0	72	0	1
14	0	0	75	0	1
21	0	0	80	0	1
22	0	0	83	0	1
24	0	0	93	0	1
27	0	0	94	0	1
33	0	0	100	0	1
34	0	0	103	0	1
44	0	0	105	0	1
47	0	0	106	0	1
52	0	0	113	0	1
55	0	0	114	0	1
57	0	0	124	0	1
58	0	1	127	0	1
69	0	1			

Table 2 Activator IDs and their jumper positions

 **To set the Activator ID with jumpers**

- 1: Power down the Activator and disconnect the wake-up antenna.

- 2: Carefully remove the lid from the Activator case and locate the JP12-JP19 jumper block.
- 3: Using needle-nose pliers, place jumpers on headers JP12 through JP19 (Figure 7) to represent the ID number in binary. A jumper on a header represents a one and absence of a jumper is a zero. JP12 is the least significant bit and JP19 is the most significant bit.

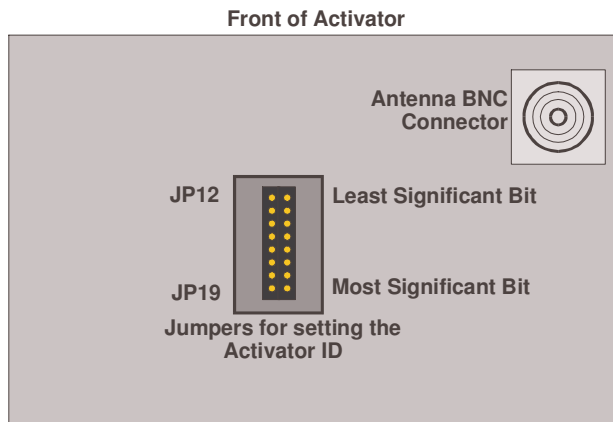

Figure 7 Activator ID Jumpers

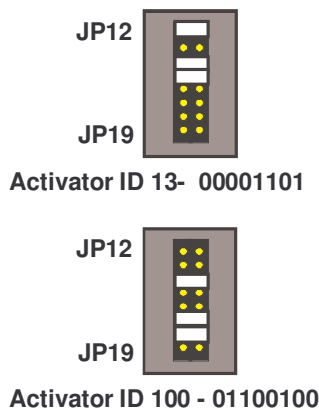

Figure 8 Examples of Activator IDs set with Jumpers



IMPORTANT! Ensure that the Receiver is configured to accept the new Activator ID so that it may process the Tag data properly. Please see the *Network Receiver Installation Manual* for instructions on programming the Receiver to respond to the new Activator ID.

Serial Port Commands

There are commands available to list a help screen and change the baud rate of the Activator's serial port.

Receiving Help

Typing a question mark “?” displays a help screen listing all commands available for the Activator:

c = 4800cps

d = 9600cps

e = 19200cps

<Num>! = ID

Changing the Baud Rate

To connect the Activator to another serial device, you can change the Activator's baud rate to match the baud rate of the device by entering one of the following commands:

Baud Rate	Command
4800	c
9600	d
19200	E (Default baud rate)

NOTE After you have set the baud rate, you will need to adjust the port settings of the serial device.

Activator Installation

The Activator originates the signal that is broadcast by the transmit antenna. The Activator should be installed as close as possible to the transmit antenna, and up to 50 feet away by cable distance from the antenna. Contact Distributor Support for assistance with extended distance installations. The shorter the cable, the better the system will perform.

Required Materials

The following materials are necessary for a successful installation:

- Power drill and bits
- Screwdrivers – Phillips and flathead
- Two screws (for wall mount)

NOTE Depending on the surface that the Activator will be mounted on, you may want to use #10 molly bolts.

Mounting the Activator



IMPORTANT! Before permanently mounting any piece of the ActiveTag System, first lay out and test the entire system.

The Activator should be a maximum of 50 feet from the transmit antenna for best performance.

Holes on the bottom of the Activator allow it to be mounted vertically to a wall or other surface.



IMPORTANT! Cycle the power on the Activator after attaching the transmitting antenna.



To install the Activator

1. Install the Activator as close as possible to the transmit antenna. A maximum distance of **50 feet** for best performance.
2. Cycle the power on the Activator after attaching the transmitting antenna in order for the antenna's auto-tune feature to function.
3. Check the strength of the TX Output LEDs located on the front panel of the Activator (Figure 9). A minimum of four lit LEDs is desired.



Figure 9 TX Output LEDs on the front of the Activator

Activation Field Size

The Tag activation area can be controlled by adjusting the size of the activation field. For example, you may want to shrink the activation field to concentrate the field near a doorway, preventing activation of tags further up the hall.

NOTE Each Activator is shipped from the factory with its activation control adjusted to its highest level.

Adjusting the Field

The size of the activation field is controlled by the TX CNTL screw on the back of the Activator (Figure 10). The screw can turn in one direction 30 times. After it has been turned 30 times in one direction, it will make a soft clicking sound. The clicks indicate that continuing in this direction will no longer have an effect on the field's size. When you hear this sound, the wake-up field has been adjusted to one extreme or the other.

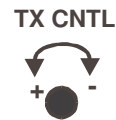

Figure 10 Adjust the size of the activation field

To Reduce the Activation Field

Rotate the TX CTRL screw **clockwise** with the supplied tuning wand. Constantly check the field with an LED Test Tag to ensure that the field is the size that you want.



TIP The system will stop functioning if the activation control is turned down too low. To fix this, turn the screw counter-clockwise until it clicks. Then slowly reduce the field by tuning the TX CNTL screw clockwise while checking its size.

To Enlarge the Activation Field

Rotate the TX CTRL screw **counter-clockwise** with the supplied tuning wand. When it clicks, it has been tuned up as high as possible.

After Adjusting the Field

Cycle the power on the Activator after the field has been adjusted.

Index

- Activation Field Size, 17
 - Adjusting the Field, 17
- Adjustable Power, 8
- Changing Activator ID Numbers, 12
- Configuring Activator, 9
- Connecting Computer to Activator, 10
- Connecting Power, 9
- Control Point Architecture, 8
- Features, 7
- Flexible Installation, 8
- Front Panel, 7
- Hotline, 2
- Information Flags, 4
- Installation, Activator, 16
- Jumper Positions, 13
- Materials
 - Provided, 5
 - Recommended, 6
 - Required, 5
- Mounting the Activator, 16
- Rear Panel, 7
- Receiving Help, 15
- Safety, 4
- Serial Port Commands, 15
- Setting Activator ID
 - Jumpers, 13
 - Serial Commands, 10
- Signal Penetration, 8
- Specifications, 7
- Windows HyperTerminal, 11